

**TECHNICAL GUIDE  
&  
PARTS CATALOGUE**

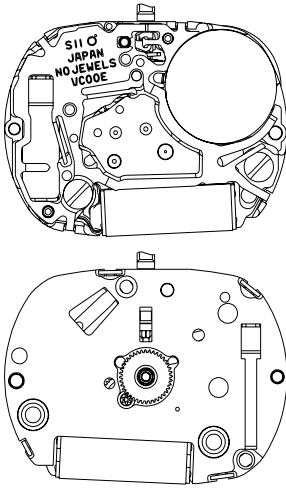
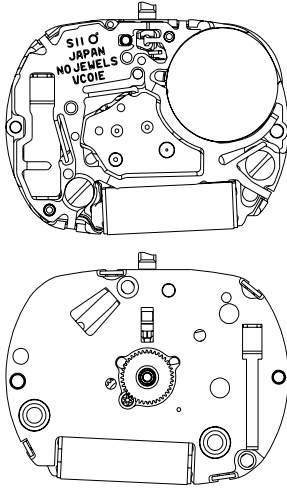

**Cal.VC00/01E**

**ANALOGUE QUARTZ**

**SII Products**

Item		Cal. No.	VC00E	VC01E
Movement				
Movement size	Outside diameter	10.8 mm : between 3 o'clock and 9 o'clock sides 14.5 mm : between 6 o'clock and 12 o'clock sides		
	Casing diameter	13.9 mm : between 6 o'clock and 12 o'clock sides		
	Total height	2.38 mm (including the battery)		
Time indication			2 Hands	3 Hands
Driving system		Step motor (Load compensated driving pulse system type)		
Additional function		Electronic circuit reset switch	Electronic circuit reset switch Second setting device	
Loss/Gain (Monthly rate) Frequency of crystal oscillator		Less than 20 seconds at normal temperature range 32,768 Hz		
Operational temperature range		-5°C ~ +50°C		
Regulation system		Nil		
Measuring gate by QUARTZ TESTER		Use 10-second gate		
Battery		Use 10-second gate		
Battery		SR521SW (Silver oxide battery) Battery life is approximately 2 years Voltage : 1.55 V		
Jewels		0 jewel		

Disassembling procedures Figs. ① ⇒ ②⑤  
Reassembling procedures Figs. ②⑤ ⇒ ①

Lubricating : Types of oil Oil quantity  
 Moebius 9010  Normal quantity  
 Moebius 9030

[ Cal.VC01E ]

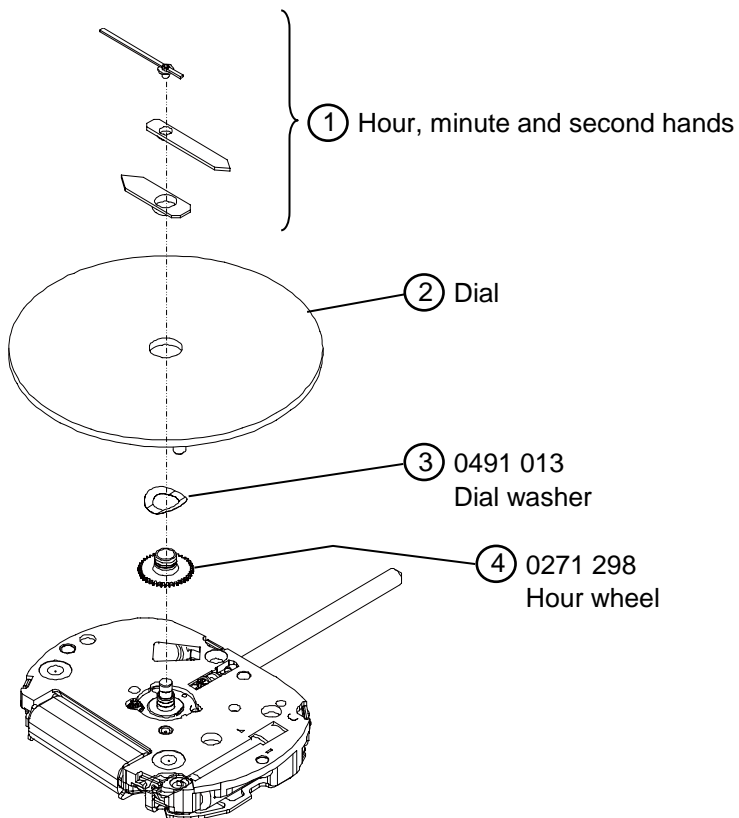

[ Cal.VC00E ]

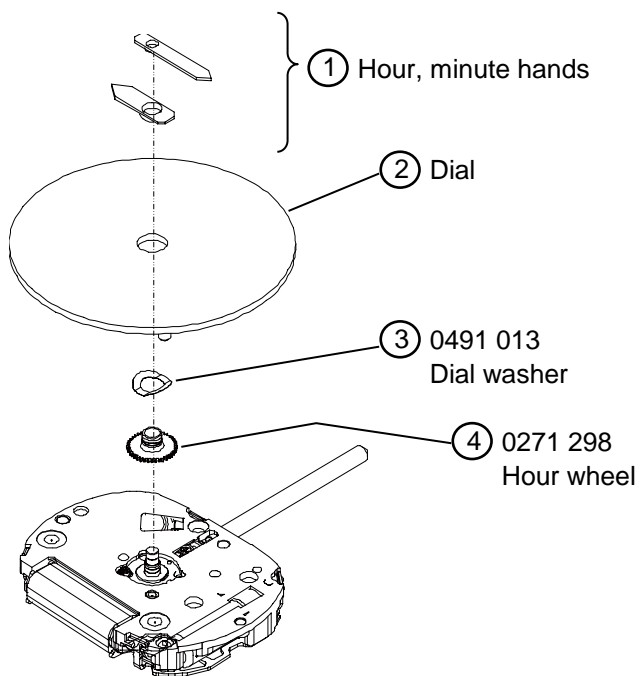

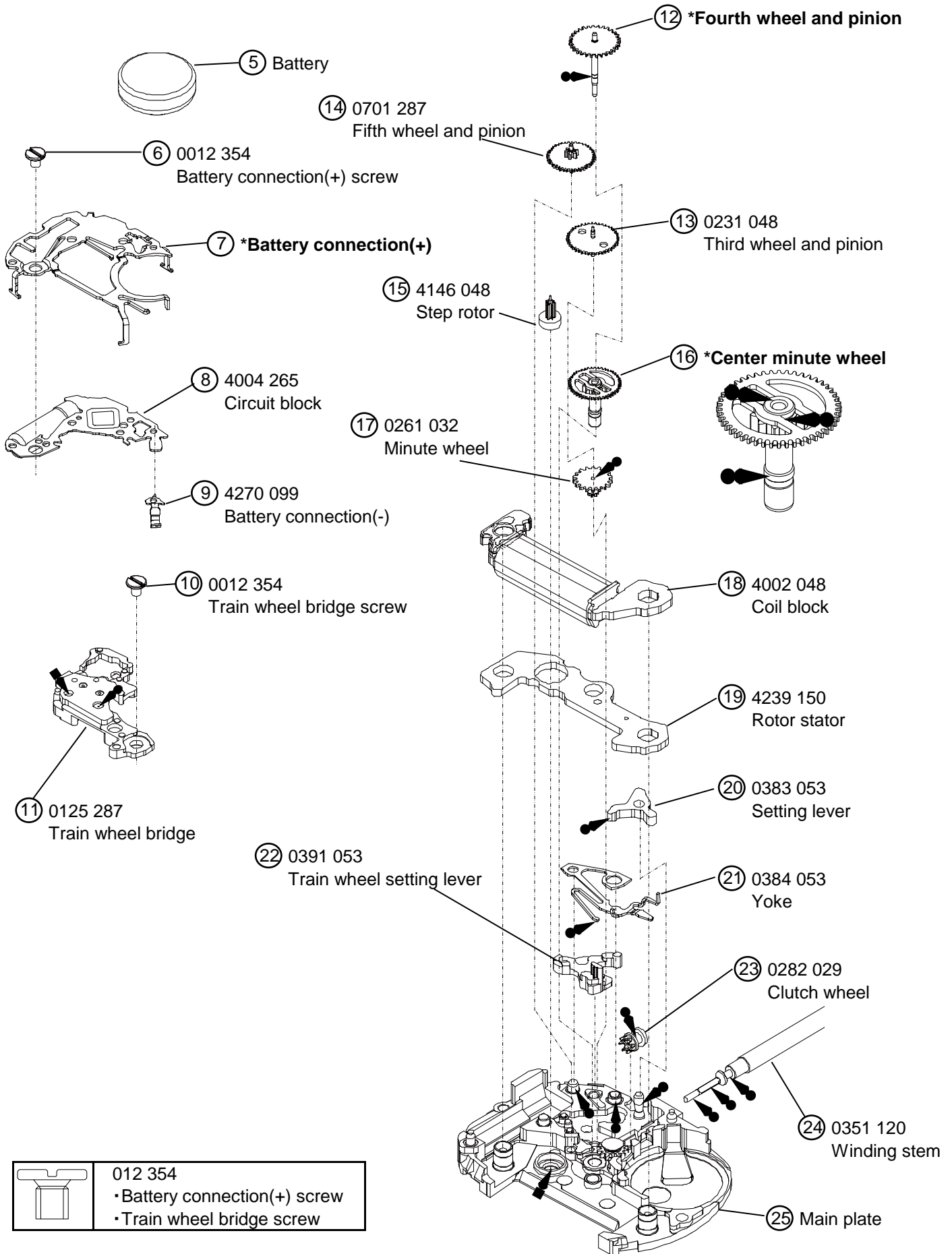

Remarks :

Fourth wheel and pinion  
Center minute wheel  
Battery connection(+)

**[ Cal.VC00E ]**

Center minute wheel : 0270 082  
Fourth wheel and pinion : 0241 329  
Battery connection(+) : 4271 219

**[ Cal.VC01E ]**

Center minute wheel : 0270 298  
Fourth wheel and pinion : 0241 133  
Battery connection(+) : 4271 218

**\* All parts code are subject to change without notice.**

•The explanation here is only for the particular points of Cal.VC00/01E

1. STRUCTURE OF THE CIRCUIT BLOCK

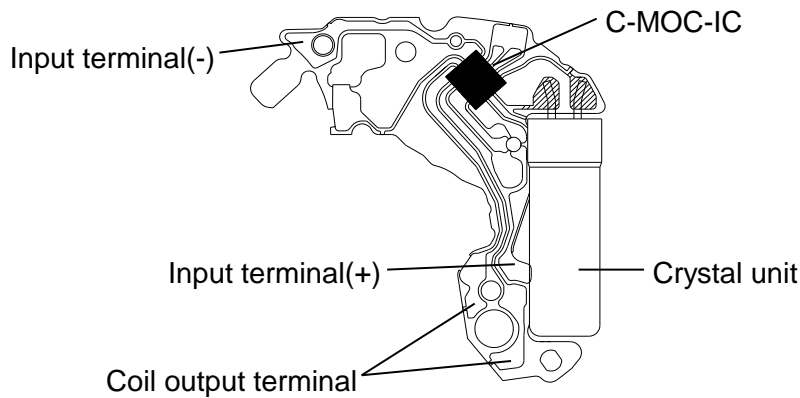

2. REMARKS ON DISASSEMBLING AND REASSEMBLING

(1) Hands

•How to install

Notes:

•When installing the hands, place the movement directly on a flat metal plate or the like, escaping the spring portion of the battery connection(+).

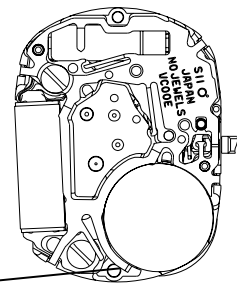

Spring portion of battery connection(+)

(2) Battery

•How to install

Notes:

•When installing the battery, check that the battery connection(+) securely touches the side face of the battery.

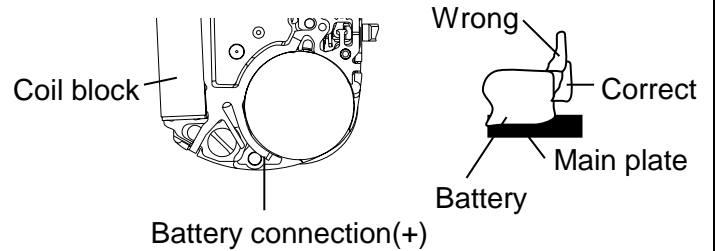

(3) Battery connection(+)

•How to install

Notes:

•Have the hook portions (4places) catch the main plate

•In disassembling and reassembling, take care not to deform the hook portions.

•After installing the battery connection(+), check that the four hook portions securely catch the main plate.

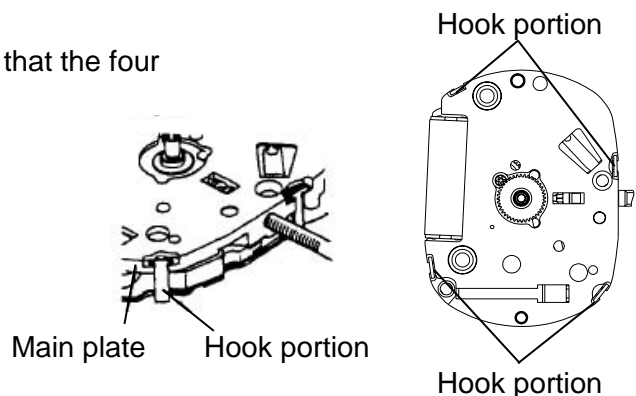

(4) Train wheel bridge

- Setting position

Notes:

- Since the fifth wheel and pinion and step rotor are made of plastics, take care not to damage them in disassembling and reassembling.

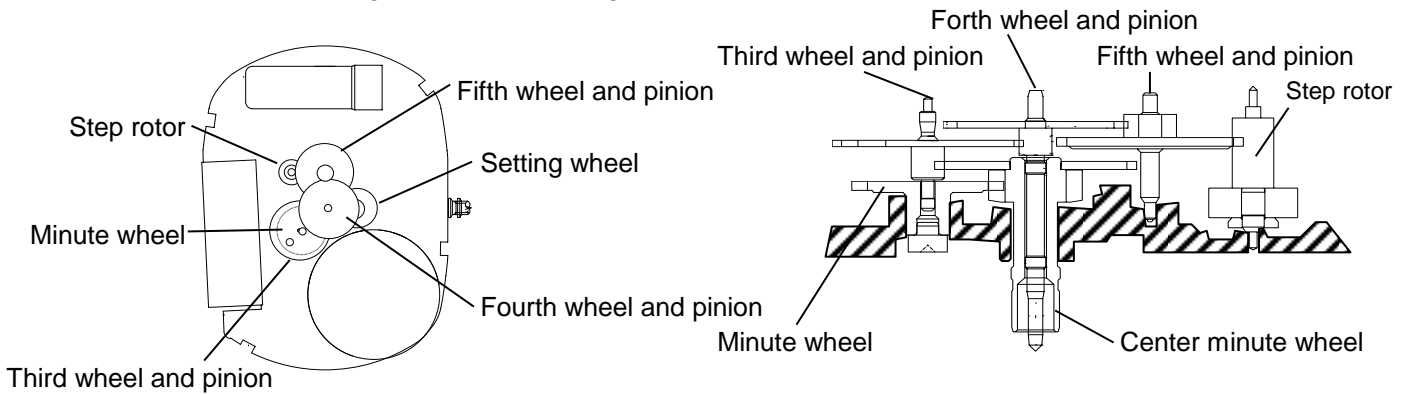

(5) Setting lever

(6) Yoke

(7) Train wheel setting lever

- Setting position

Notes:

- Take care not to deform the spring portion of the Yoke.
- Since the train wheel setting lever is made of plastics and easily damaged, Lightly catch it with tweezers taking care not to touch the portion engaging with the fifth wheel and pinion.

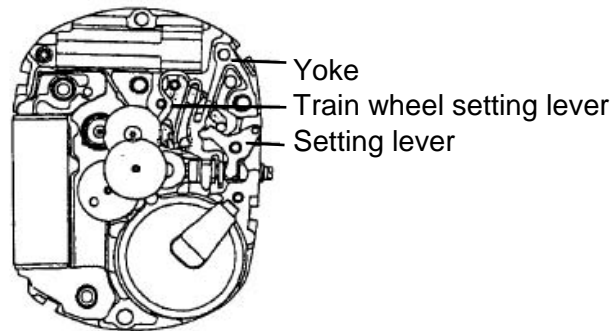

(8) Main plate

- Lubricating

Notes:

- Since the setting wheel is fixed securely to the main plate with a pin, never disassemble them apart.
- Apply a liberal quantity of Moebius A to the setting wheel.

