

**TECHNICAL GUIDE
&
PARTS CATALOGUE**

CaI.VJ76B

ANALOGUE QUARTZ

SII Products

Cal.VJ76B

[SPECIFICATION]

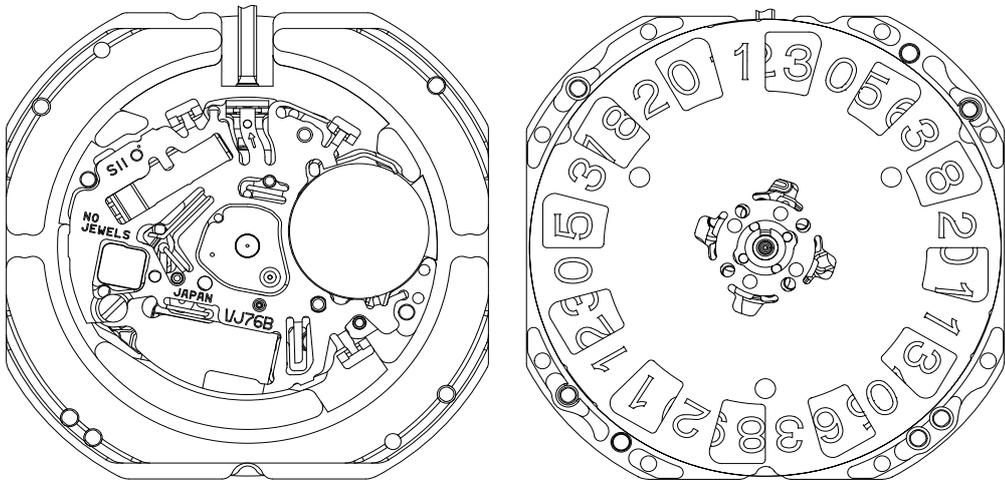
Item		Cal. No.	Cal.VJ76B
Movement			
Movement size	Outside diameter		φ26.40 mm 23.50 mm : between 12 o'clock and 6 o'clock sides 23.50 mm : between 3 o'clock and 9 o'clock sides
	Casing diameter		φ25.60 mm 23.50 mm : between 12 o'clock and 6 o'clock sides 21.90 mm : between 3 o'clock and 9 o'clock sides
	Total height		3.50 mm
Time indication			3hands (hour , minute , second) Big date calendar
Driving System			Step motor
Additional mechanism			Electronic circuit reset switch Second setting device Date setting
Antimagnetic			≥1600 A/m
Accuracy			Less than ±20seconds : Monthly rate at normal temperature range
Battery			SR621SW (Silver oxide battery) Battery life is approximately 3 years
Measuring gate by quartz tester			Use 10-second gate * Set the winding stem with crown at the normal position
Jewels			0 Jewel

Disassembling procedures Figs. ① → ③④

Reassembling procedures Figs. ③④ → ①

Lubricating : Types of oil

- Moebius 9010
- Moebius 9030

Oil quantity

∞ NORMAL QUANTITY

***Refer to the 4pages for the each parts code**

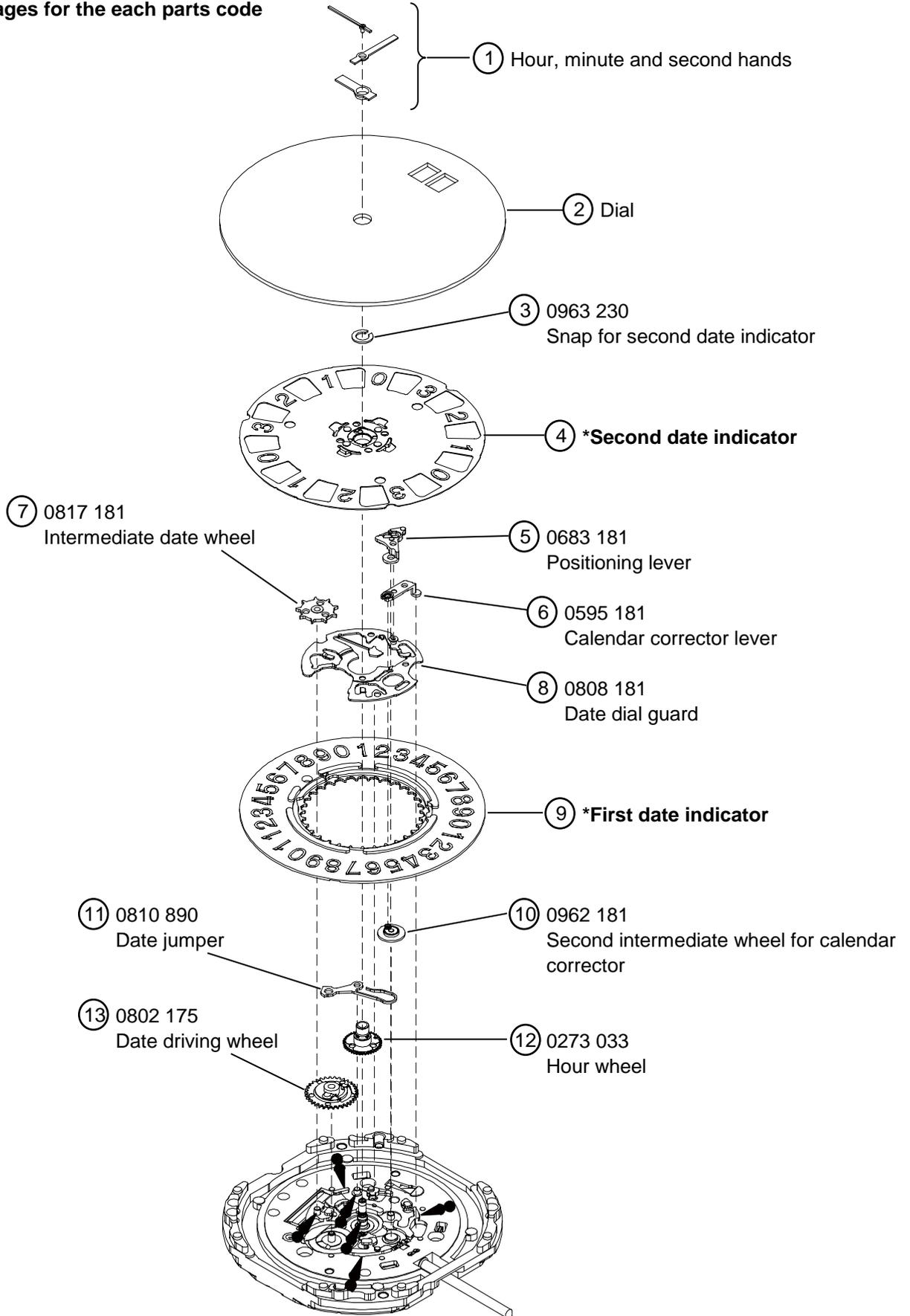

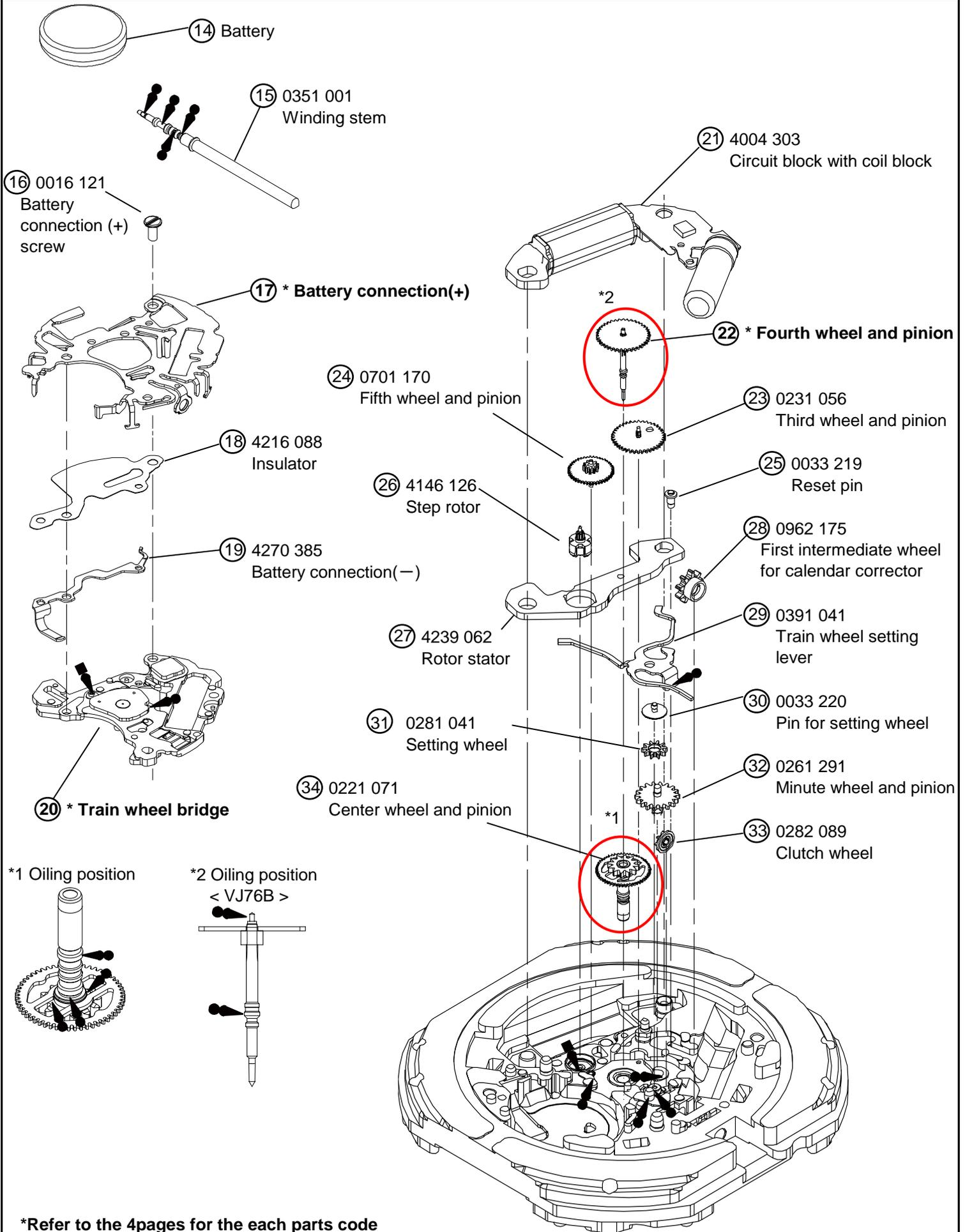

Remarks :

O Date indicator

Part code		Position of crown	Position of Date frame	Color of figure	Color of background
First date indicator	Second date indicator				
0878 123	0878 127	3H	6H	Black	White
0878 125	0878 178	3H	12H	Black	White

O The part which is not common in Cal.VJ76B

Parts name	VJ76B
⑰ Battery connection(+)	4268 063
⑳ Train wheel bridge	0125 297
㉒ Fourth wheel and pinion	0144 144

***All parts code are subject to change without notice.**

•The explanation here is only for the particular point of Cal.VJ76

I .STRUCTURE OF THE CIRCUIT BLOCK

Notes: Since the circuit block and coil block are made by one piece, in disassembling and reassembling take care not to cut the coil line.

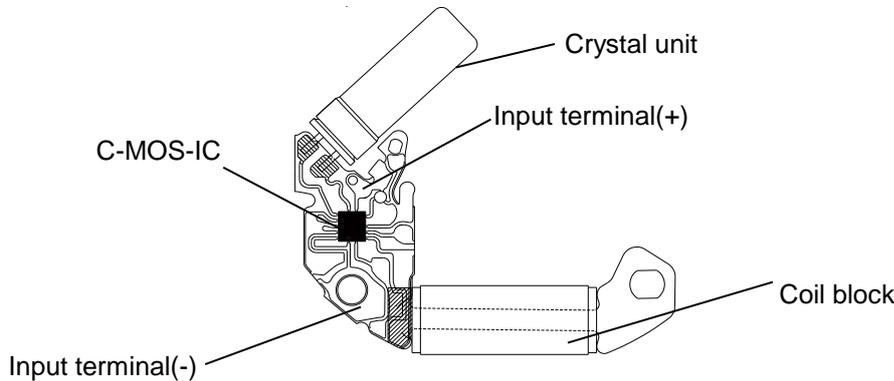

II.REMARKS ON DISASSEMBLING AND REASSEMBLING

①HAND

•How to install hands

Place the movement directly on a flat metal plate or the like to install the hands.

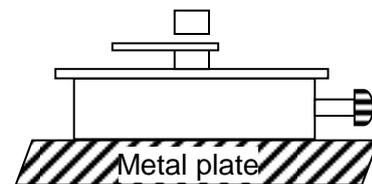

② Date dial guard

The date dial guard has three protrusions to be caught under the main plate, and it is also fixed by two guide pins.

•How to remove

1) Lightly lift the A portion of the date dial guard with tweezers to release it from the guide pin, and then move it in the clockwise direction until it gets off the guide pin.

2) Release the B portion of the date dial guard in the same way as described above, and then move it in the clockwise direction until it gets off the guide pin.

3) Check that all the three protrusions of the date dial guard have come off from the main plate, and then remove the date dial guard.

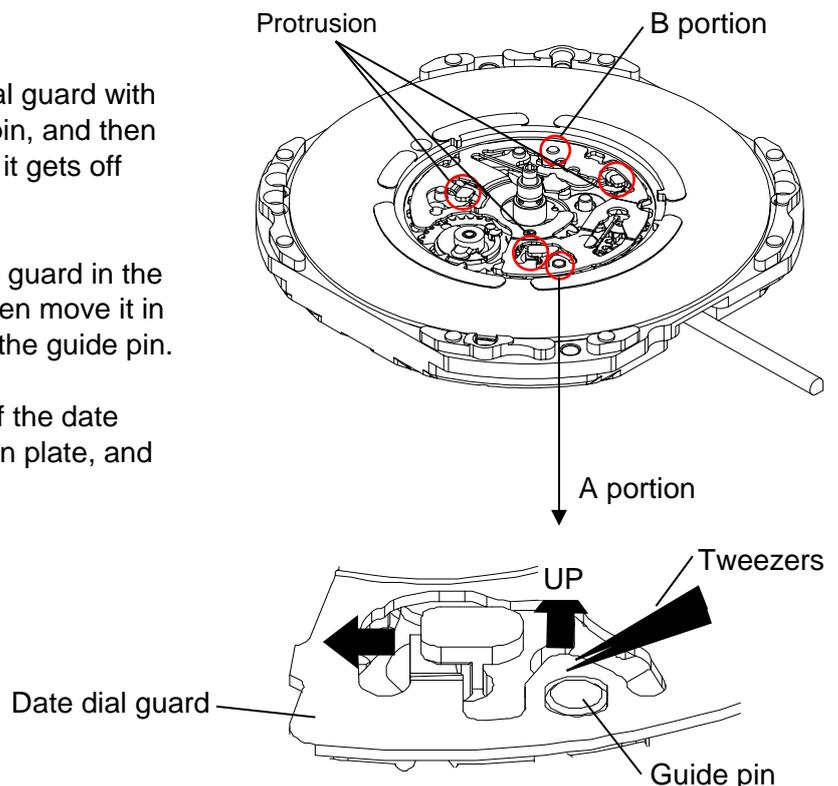

•How to install

- 1) Put the date dial guard on the main plate so that the A and B portions are over the guide pins, as shown in the illustrations at right.
- 2) Move the protrusion D of the date dial guard in the counterclockwise direction so that it is caught under the main plate.
- 3) Slightly move the protrusions C and E in the counterclockwise direction alternately to set them under the main plate. Then, set the A and B portions of the date dial guard to the guide pins.
- 4) Check that the date dial guard is fixed securely to the main plate.

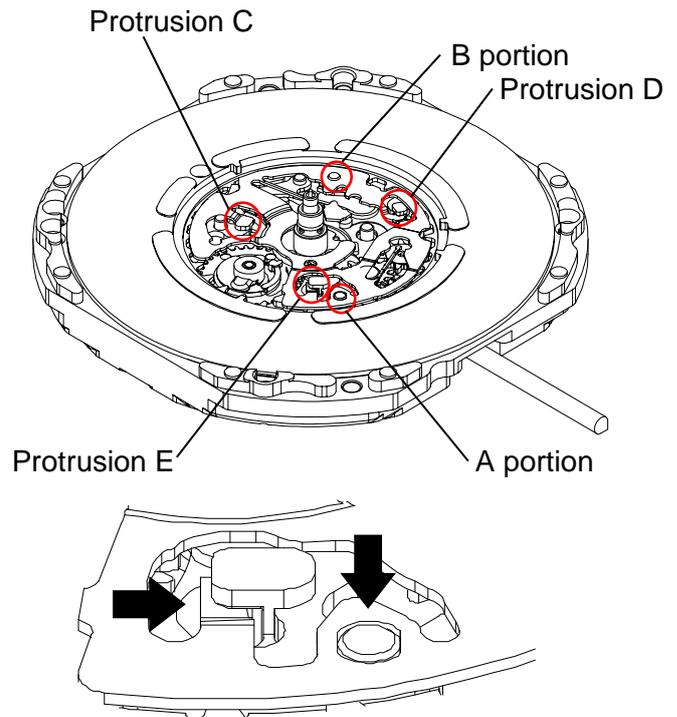

③ Battery

•How to install

Insert the battery aslant in the direction shown by the arrow.
Check the battery connection (+) securely touches the side face of the battery.

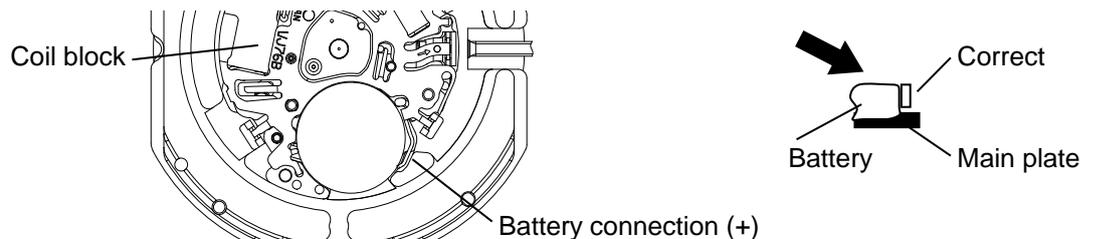

④ Battery connection (+)

•How to install

Have the hook portions (3 places) catch the main plate (Fig.1&2).
In disassembling and reassembling, take care not to deform the hook portions.
After installing the battery connection (+), check that the three hook portions securely catch the main plate.

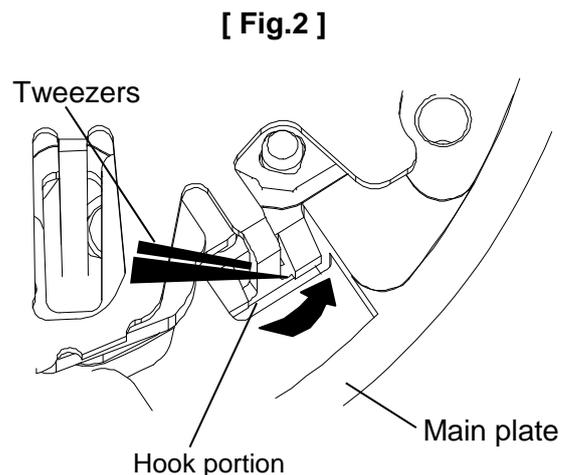
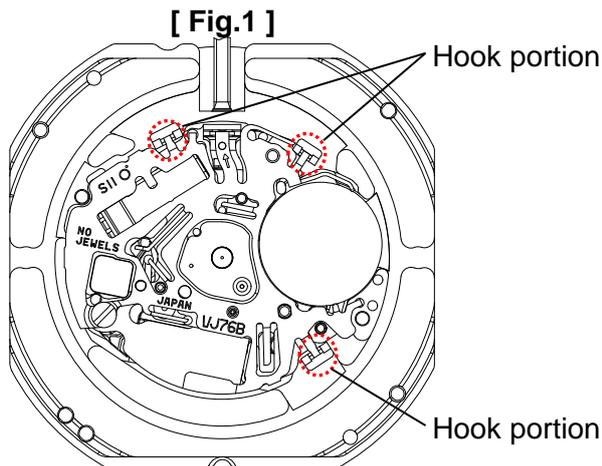

⑤ Insulator

•Setting position

Notes: To insulate between the battery connection (+) and the battery connection (-), Insulator should be put at the three pin securely as bellow.

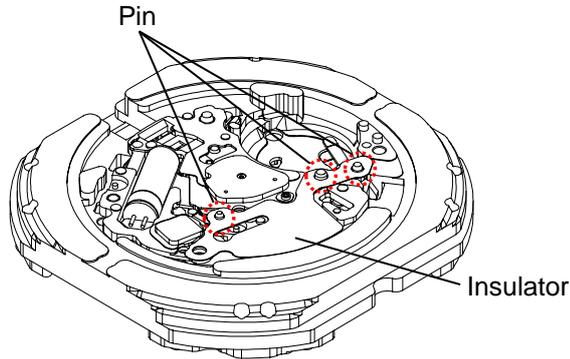

⑥ Train wheel bridge

•Setting position

Notes: Since the fifth wheel and pinion and step rotor are made of plastics, take care not to damage them in disassembling and reassembling.

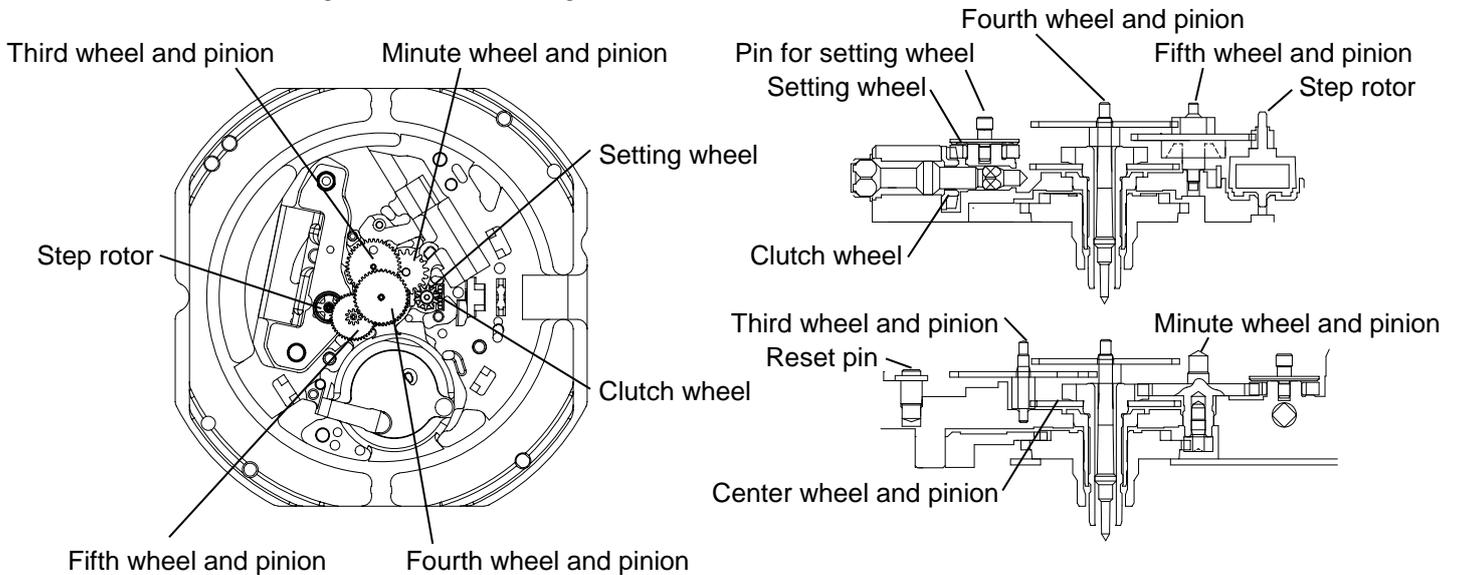

⑦ Train wheel setting lever

•Setting position

Notes:

- Catch the part of spring of the train wheel setting lever to the pin like as bellow.
- Take care not to deform the spring portion of the train wheel setting lever.

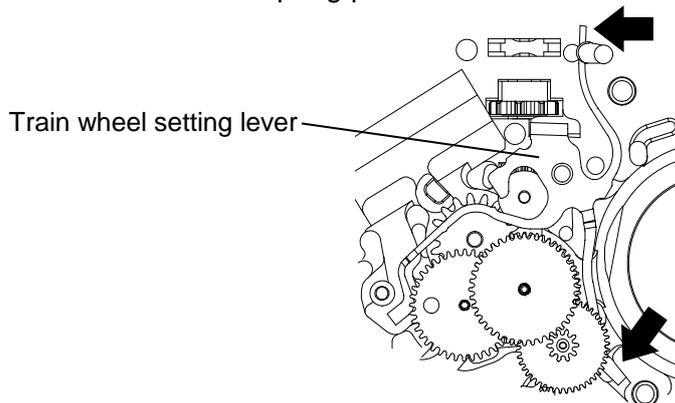

⑧ Pin for setting wheel

Notes:

- In disassembling and reassembling , take care not to damage the portion that is assembled of the pin.
- (Since the portion that is assembled of the pin is made of plastics and easily damaged.)

In disassembling ,
pick the pin up main plate to vertical direction with care .

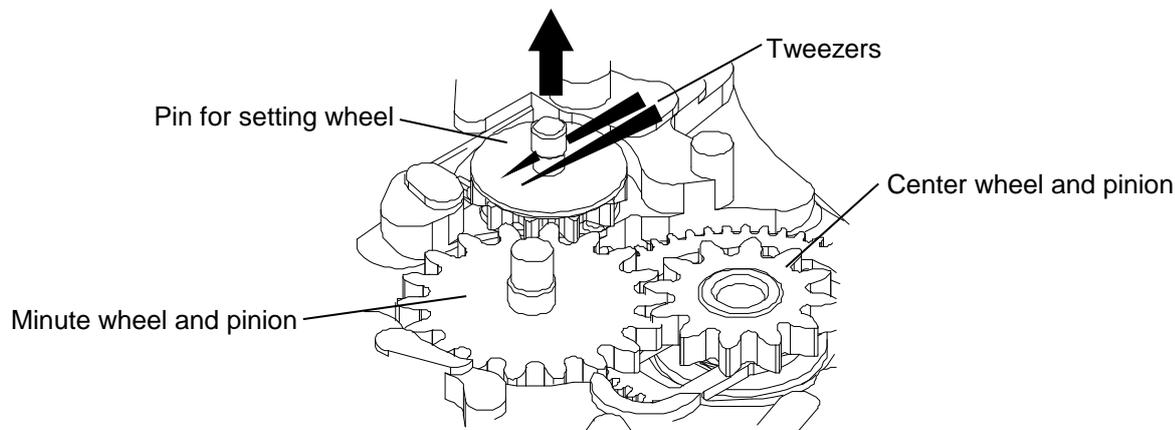

In reassembling ,
push the pin in main plate to vertical direction with care .

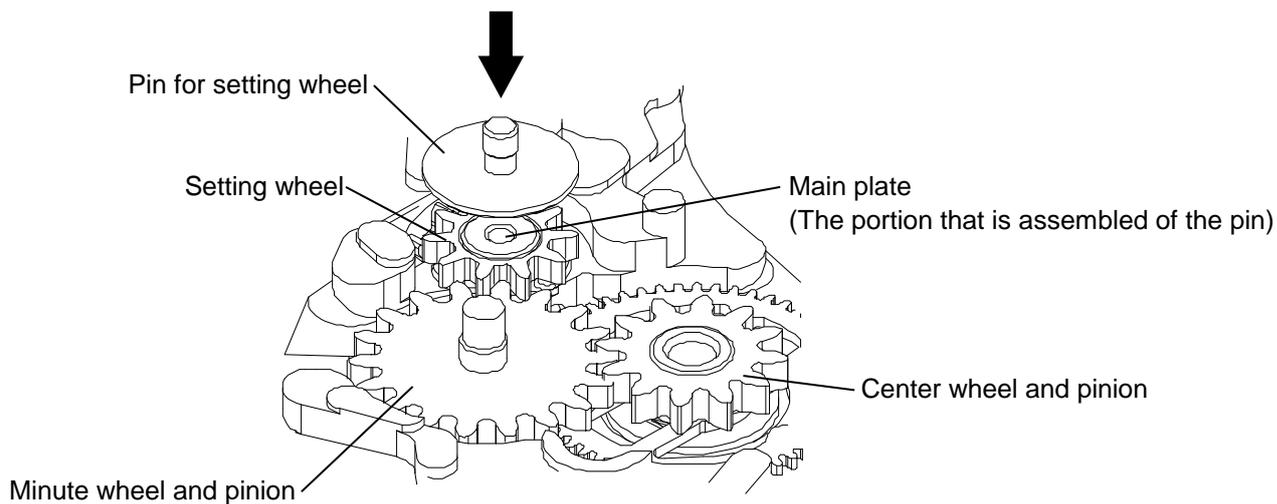

The explanation here is only for the particular point of Cal.VJ76

⑨ Setting position of the First date indicator & Second date indicator.

•How to set First date indicator & Second date indicator in position.

Note:

1. First date indicator setting.

When the First date indicator is set, the hole in First date indicator will merge with the hole in battery compartment. It takes place at 1 o'clock position of main plate.

(Pull out the crown to first click and turn the crown to set First date indicator.)

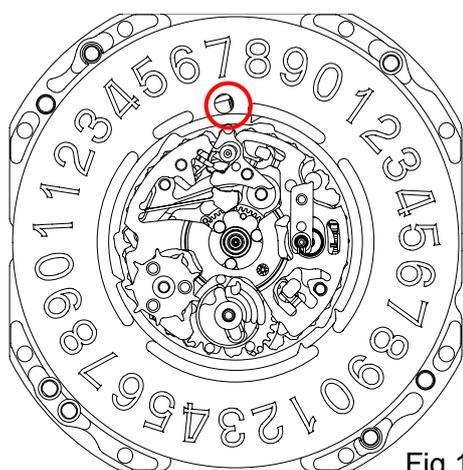

Fig.1

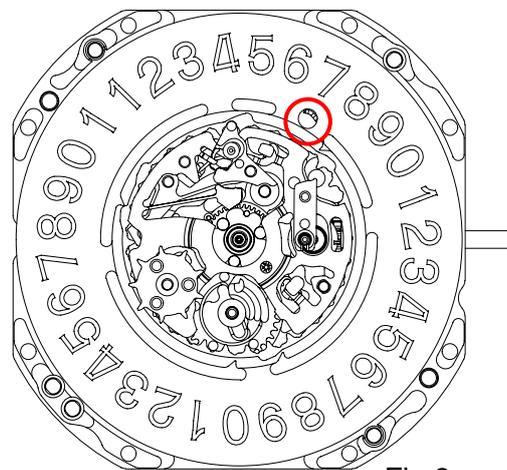
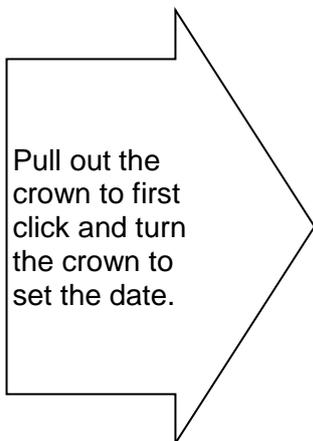

Fig.2

2. Second date indicator position setting.

After the Second date indicator was set. Rotate the Second date indicator in clockwise by touching on its surface lightly with finger. Until the Second date indicator hole overlap with the First date indicator hole at 1 o'clock position. The position is set.

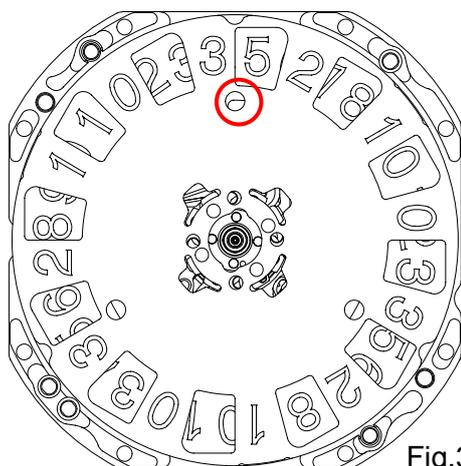

Fig.3

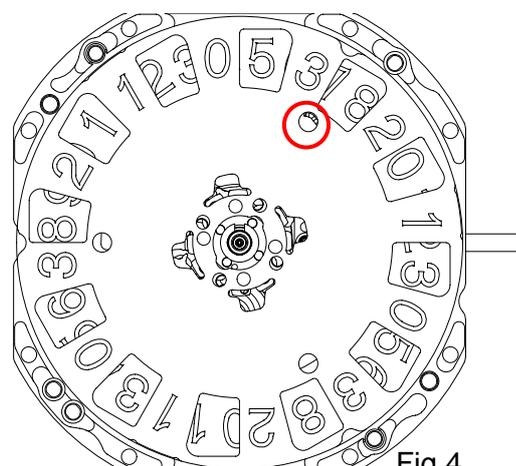
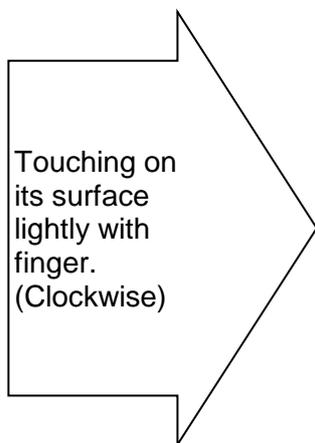

Fig.4

3. When the date indicators were set properly.

Abnormal date does not display.

For example) <00> day <32> day <33> day <34> day <39> day

(NOTE)

First date indicator cannot turn Second date indicator at any places other than Fig 2.

If it is made to rotate by force, there is a possibility that parts may break.

Cal.VJ76 watch assembly notice points

Note:

- Before a Dial set, confirm the positions of First date indicator and Second date indicator.
- Before date setting, confirm the positions of holes in 1 o'clock position.

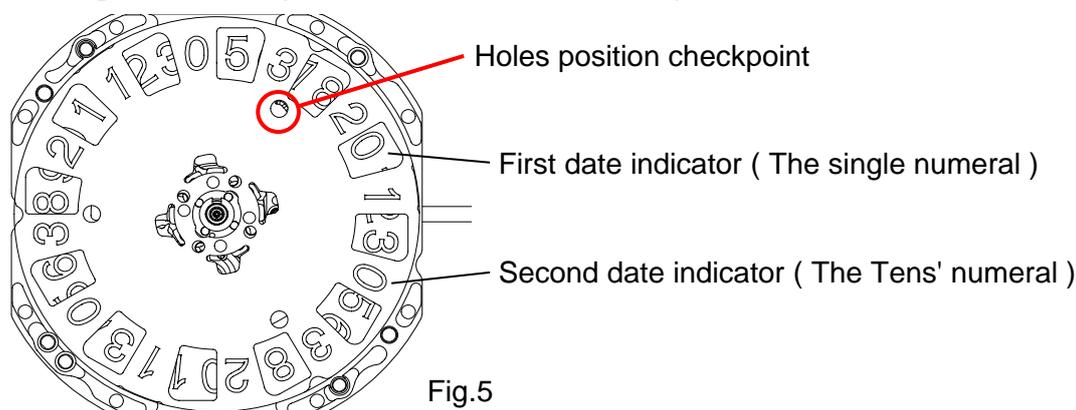

Fig.5

• When the holes are not in right position, do the following procedure.

< position setting method >

1. First date indicator position setting.

- To unify the First date disc's notch with main plate notch on edge at 9 o'clock.
(Pull out the crown to first click and turn the crown to set First date indicator.)

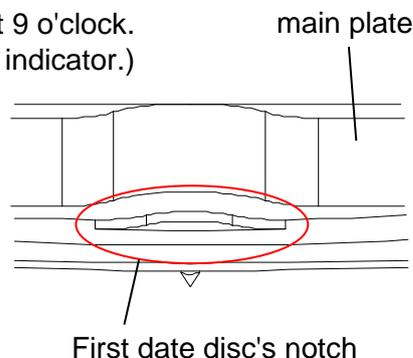
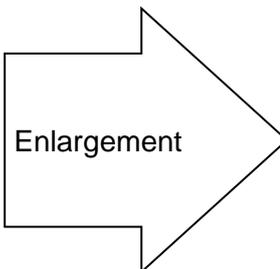
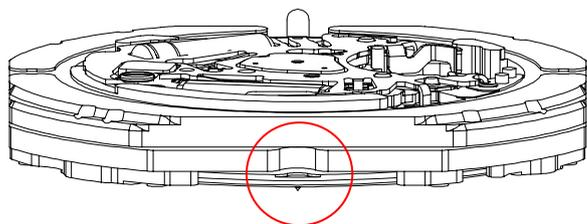

2. Second date indicator position setting.

- Rotate the Second date indicator in clockwise by touching on its surface lightly with finger.
Until the Second date indicator hole overlap with the First date indicator hole
at 1 o'clock position. The position is set.

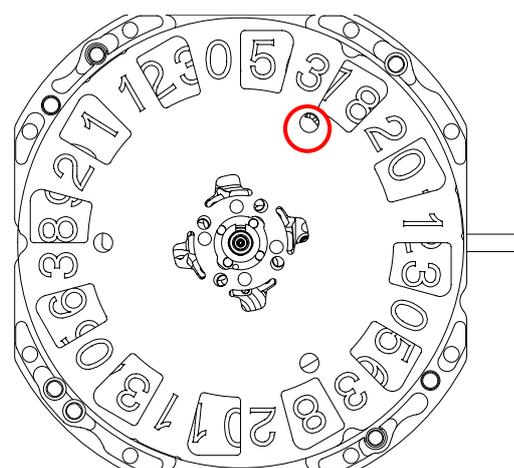
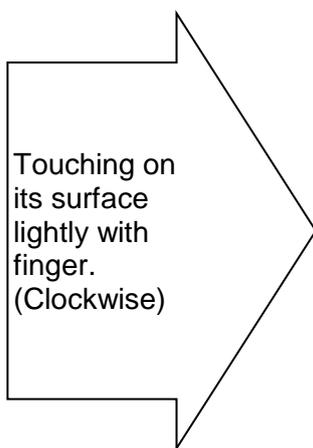
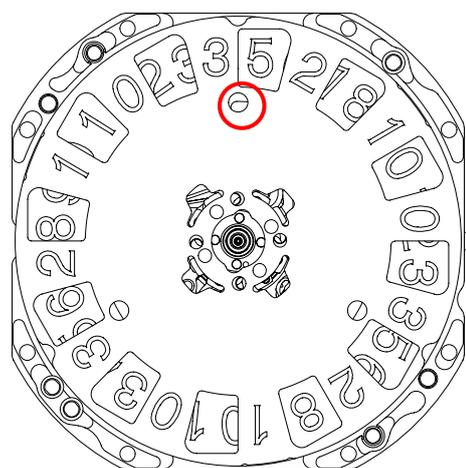

(NOTE) Second date indicator cannot be turned except the status showed in Fig 5.
Please beware not to turn the disc after the positions had been set, otherwise the date cannot be display properly.