

This drawing is provisional and subject to our reconfirmation and/or revision without notice.

xxx TIPW 1L15 (01) xxx (2100 1121) 00-06-26

DH1~DH2=16171 (±20)

Coordinates

Mark	X	Y	R
GM	0	0	—
h1	7270	4825	350
h2	-7270	4825	350
h3	-7270	-4825	350
h4	7557	-4025	325
DH1	-7900	-3000	—
DH2	8234	-1900	—
a1	2799	7550	500
a2	6600	5539	300
a3	7200	4787	300
a4	8299	3950	300
a5	8800	1632	300
a6	8800	-1632	300
a7	8299	-3950	300
a8	7200	-4787	300
a9	6600	-5539	300
a10	2799	-7550	500
a11	-2799	-7550	500
a12	-6600	-5539	300
a13	-7200	-4787	300
a14	-8299	-3950	300
a15	-8800	-1632	300
a16	-8800	1632	300
a17	-8299	3950	300
a18	-7200	4787	300
a19	-6600	5539	300
a20	-2799	7550	500
f21	5788	7505	1500
f22	5788	-7505	1500
f23	-5788	-7505	1500
f24	-6864	6800	1500

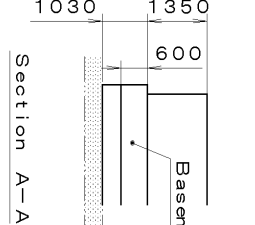
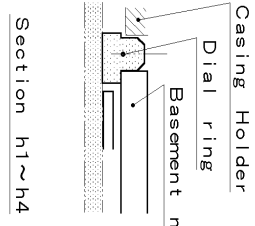
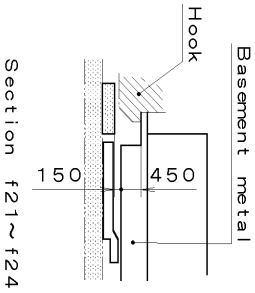
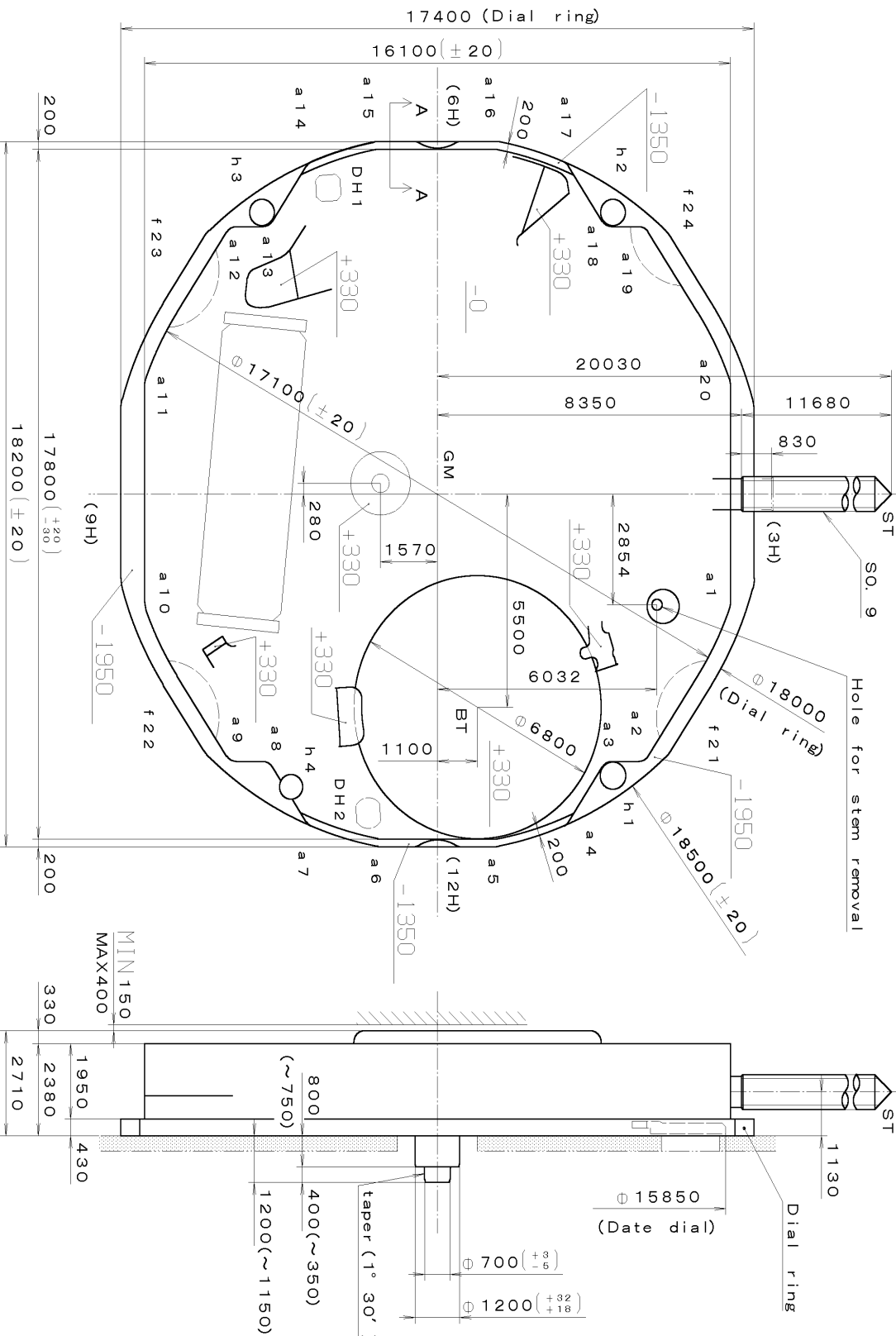

Material	Quantity	Unit	Cal. No. :
Heat Treatment		1/1000 mm	1L15
Hardness		Scale	Parts:
Plating		9:1	Date
		Drawn	Checked
		Checked	T. Hiruta
		Approved	
General Tolerances			Name:
Dimensions			Frame for Case
Angles			Drawing No. : 1L15C000

This drawing is provisional and subject to our reconfirmation and/or revision without notice.

*** T I P W (01) *** (2100 1121) 00-06-14

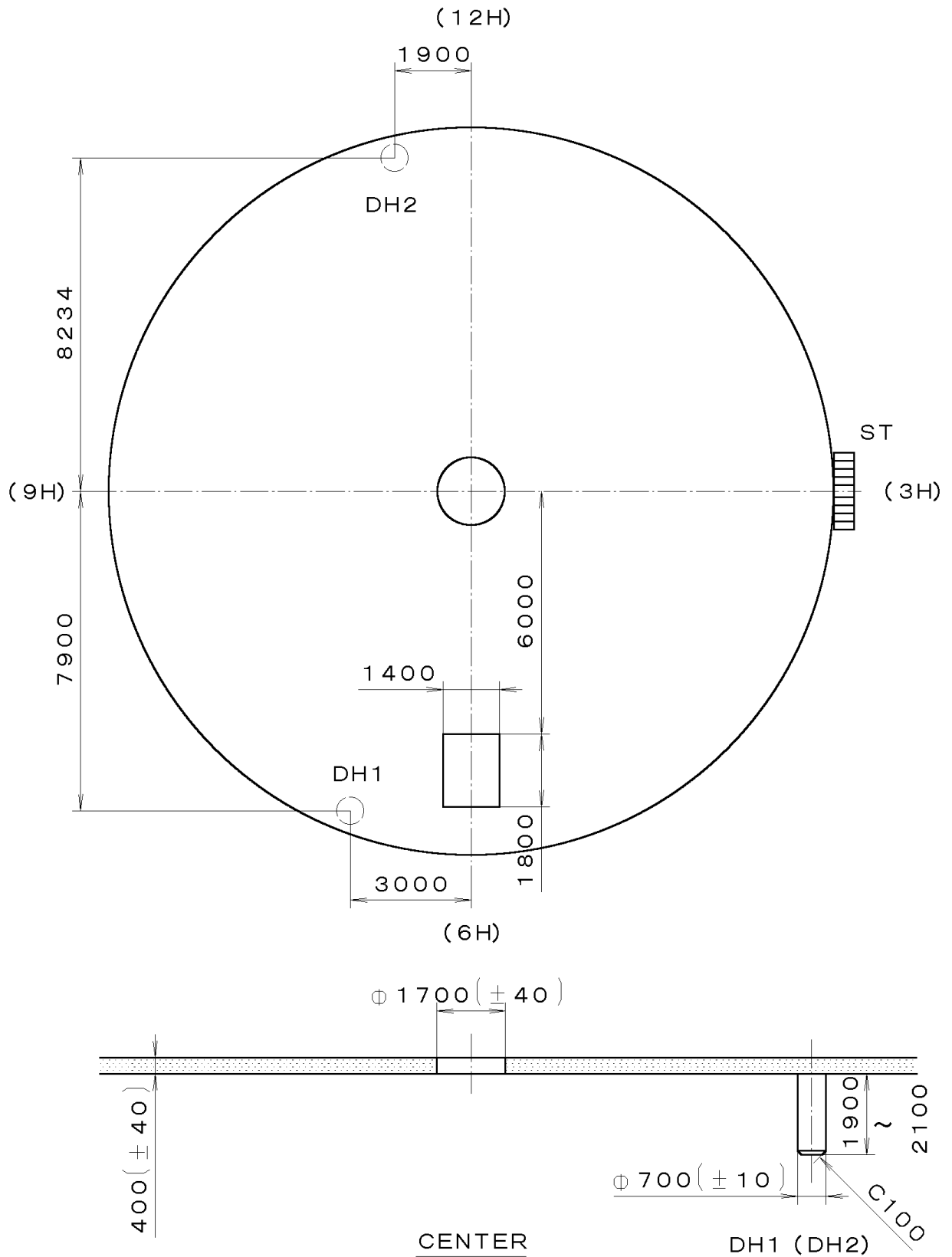

7			Quantity		Ca l. No. :	1L12-10Z
6			Unit	1/1000 mm		
5			Scale	7:1	Parts:	Name : Indications for Dial Drawing No. : 1L12D000
4			Date			
3			Drawn			
2			Checked	T. Hiruta		
1			Approved			
Material						
Heat Treatment			General Tolerances			
Hardness			Dimensions			
Plating			Angles			

This drawing is provisional and subject to our reconfirmation and/or revision without notice.

*** TIPW (01) 1L12-10A (2100 1121) 00-06-16

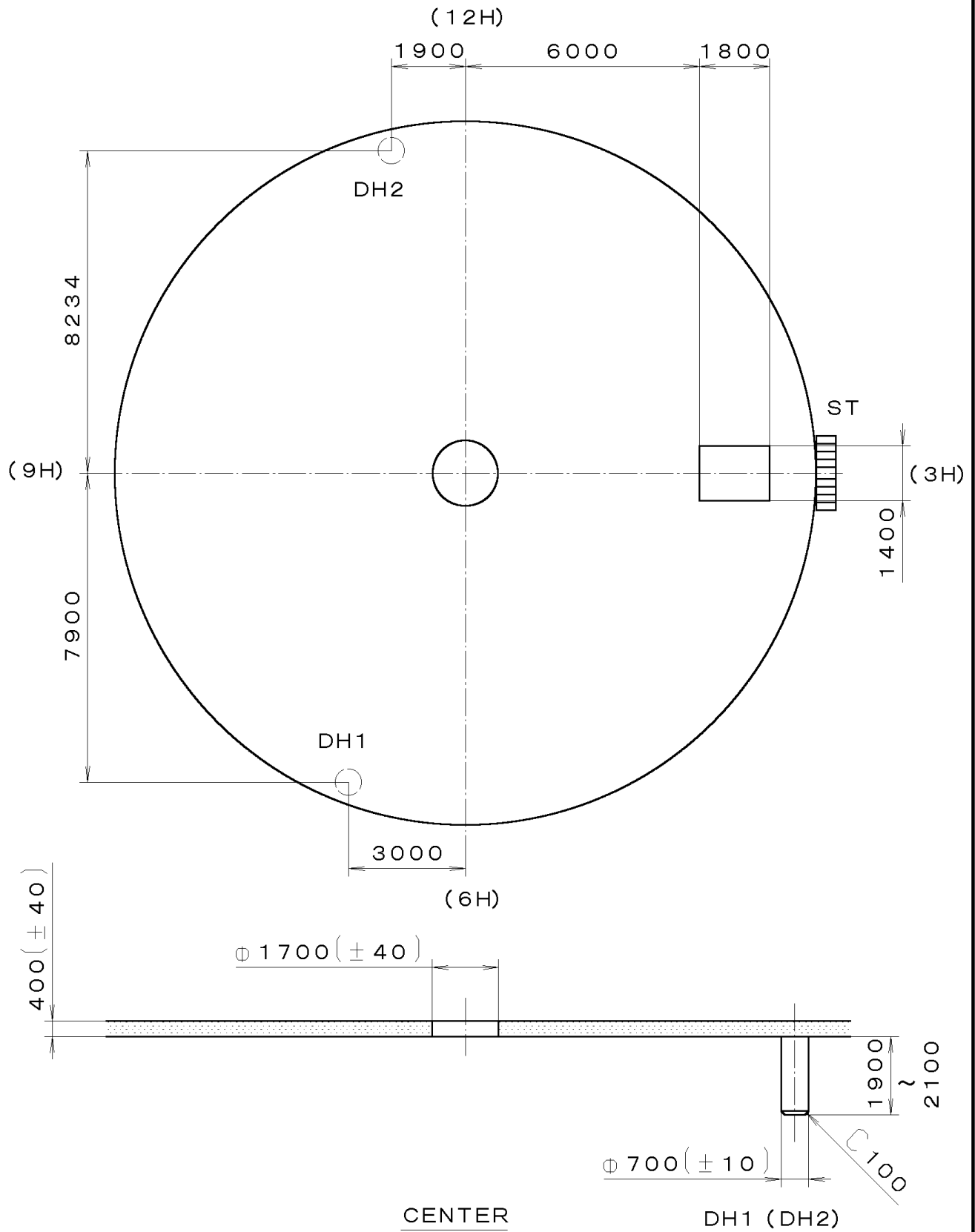

7		Quantity		Cal. No. :	1L12-10A
6		Unit	1/1000 mm	Parts:	
5		Scale	7:1	Name:	Indications for Dial
4		Date		Drawing No. : 1L12D010	
3		Drawn			
2		Checked	T. Hiruta		
1		Approved			
Material					
Heat Treatment		General Tolerances			
Hardness		Dimensions			
Plating		Angles			

This drawing is provisional and subject to our reconfirmation and/or revision without notice.

*** T I P W (01) *** (2100 1121 A-01 A-01) 00-06-22

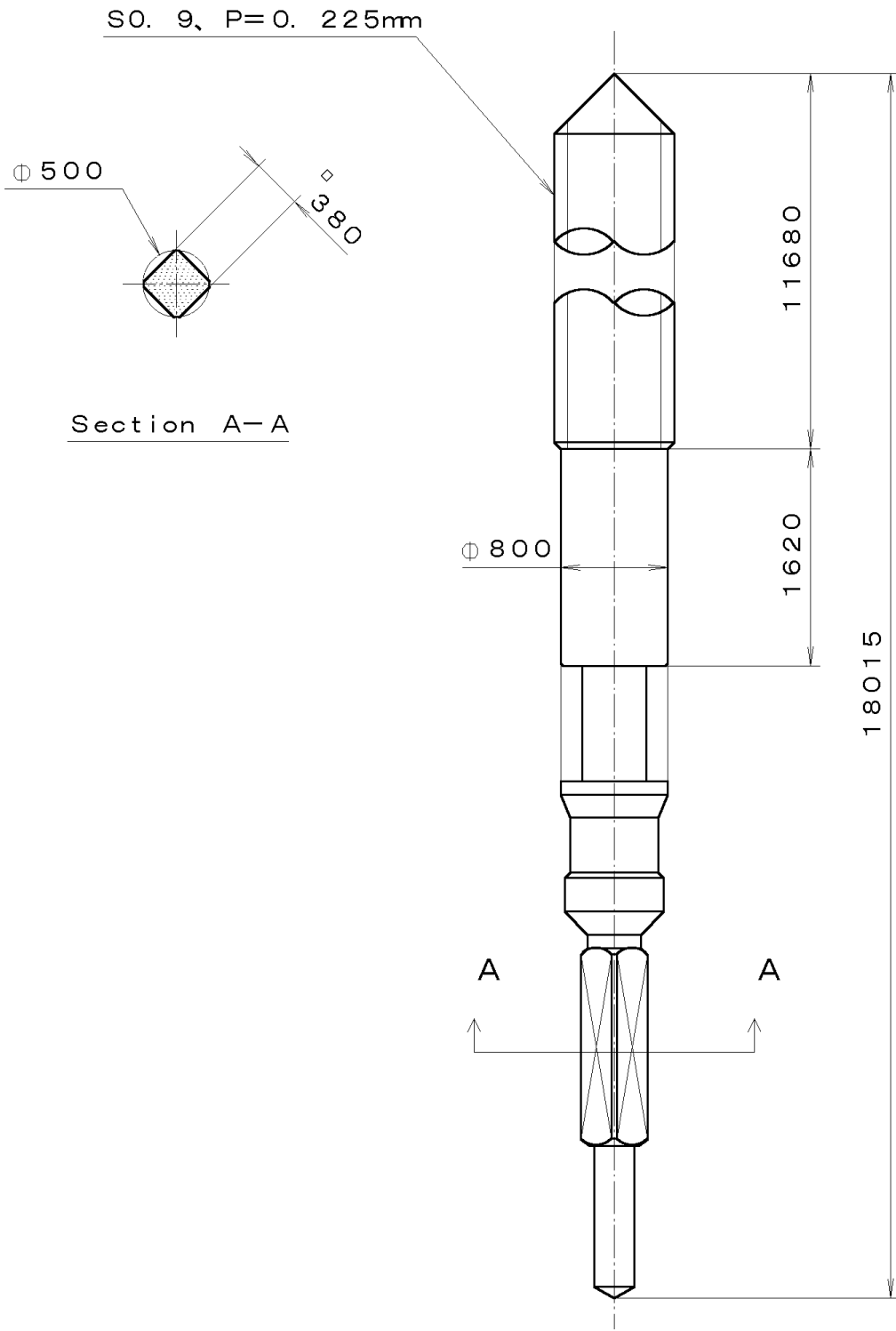

7			Quantity		Ca l. No. :
6			Unit	1/1000 mm	
5			Scale	20:1	Parts:
4			Date		065-505
3			Drawn		
2			Checked	T. Hiruta	Name:
1			Approved		SETTING STEM
Material					Drawing No. : 5050S000
Heat Treatment			General Tolerances		
Hardness			Dimensions		
Plating			Angles		