

This drawing is provisional and subject to our reconfirmation and/or revision without notice.

*** TIPW 1M15 (01) *** (2100 1121 C-01) 00-06-26

DH3~DH4=22287 (±20)

Coordinates

Mark	X	Y	R
GM	0	0	—
DH3	-8759	6900	—
DH4	8251	-7500	—
b1	8032	7877	500
b2	8624	7608	150
b3	10099	5501	150
b4	10149	4853	500
b5	7809	-8098	500
b6	7535	-8688	150
b7	5416	-10145	150
b8	4768	-10180	500
b9	-8032	-7877	500
b10	-8624	-7608	150
b11	-10099	-5501	150
b12	-10149	-4853	500
b13	-7809	8098	500
b14	-7535	8688	150
b15	-5416	10145	150
b16	-4767	10180	500

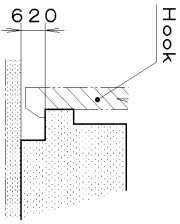

Section b1~b16

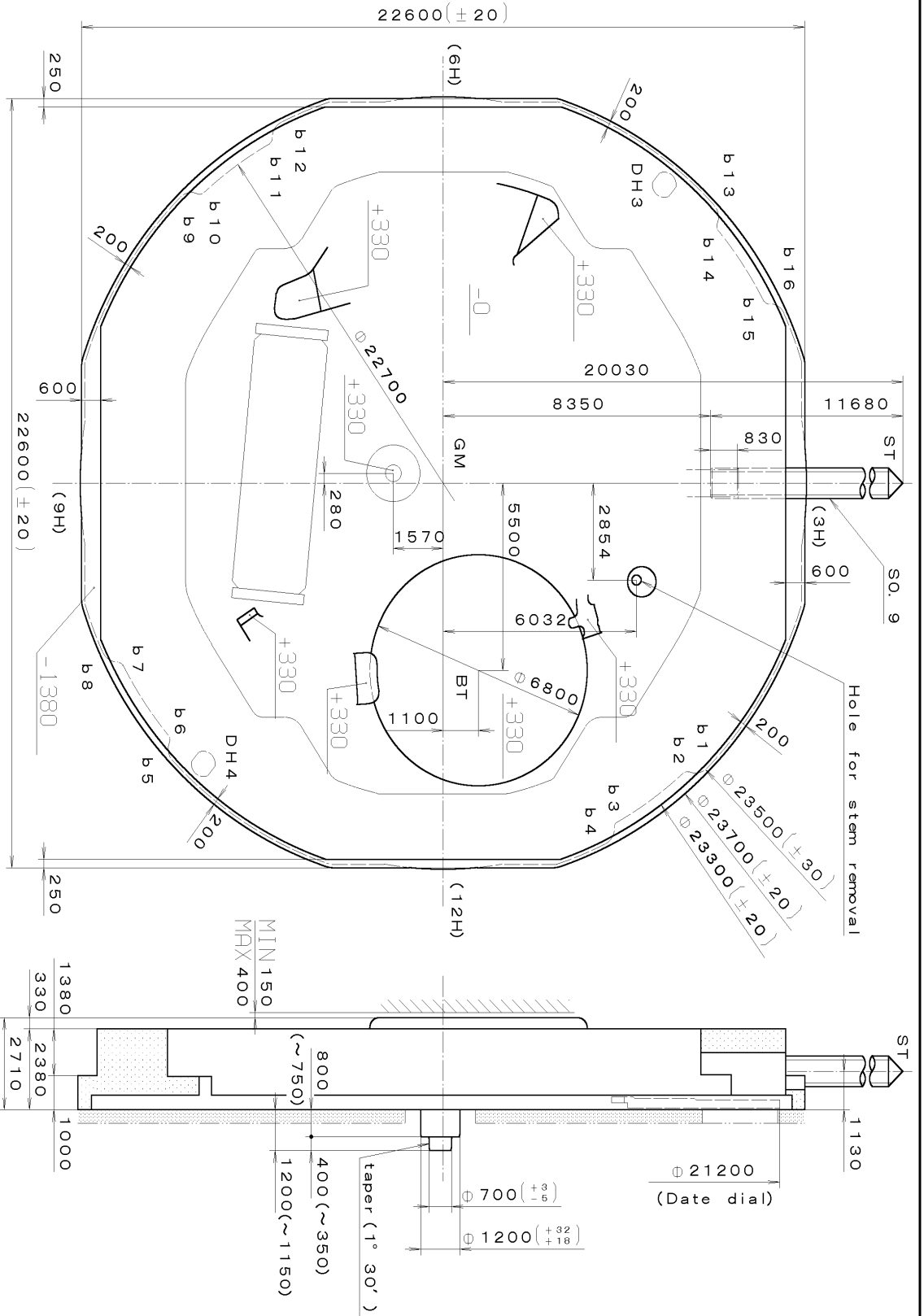

△	Quantity	1/1000 mm	Cal. No. : 1M15
△	Unit	8:1	Parts:
△	Scale		Name:
△	Date		Frame for Case
△	Drawn	T. Hiruta	Drawing No. : 1M15C0000
△	Checked		
△	Approved		
△	Material	General Tolerances	
△	Heat Treatment	Dimensions	
△	Hardness	Angles	
△	Plating		

This drawing is provisional and subject to our reconfirmation and/or revision without notice.

*** T I P W (01) *** (2100 1121) 00-06-29

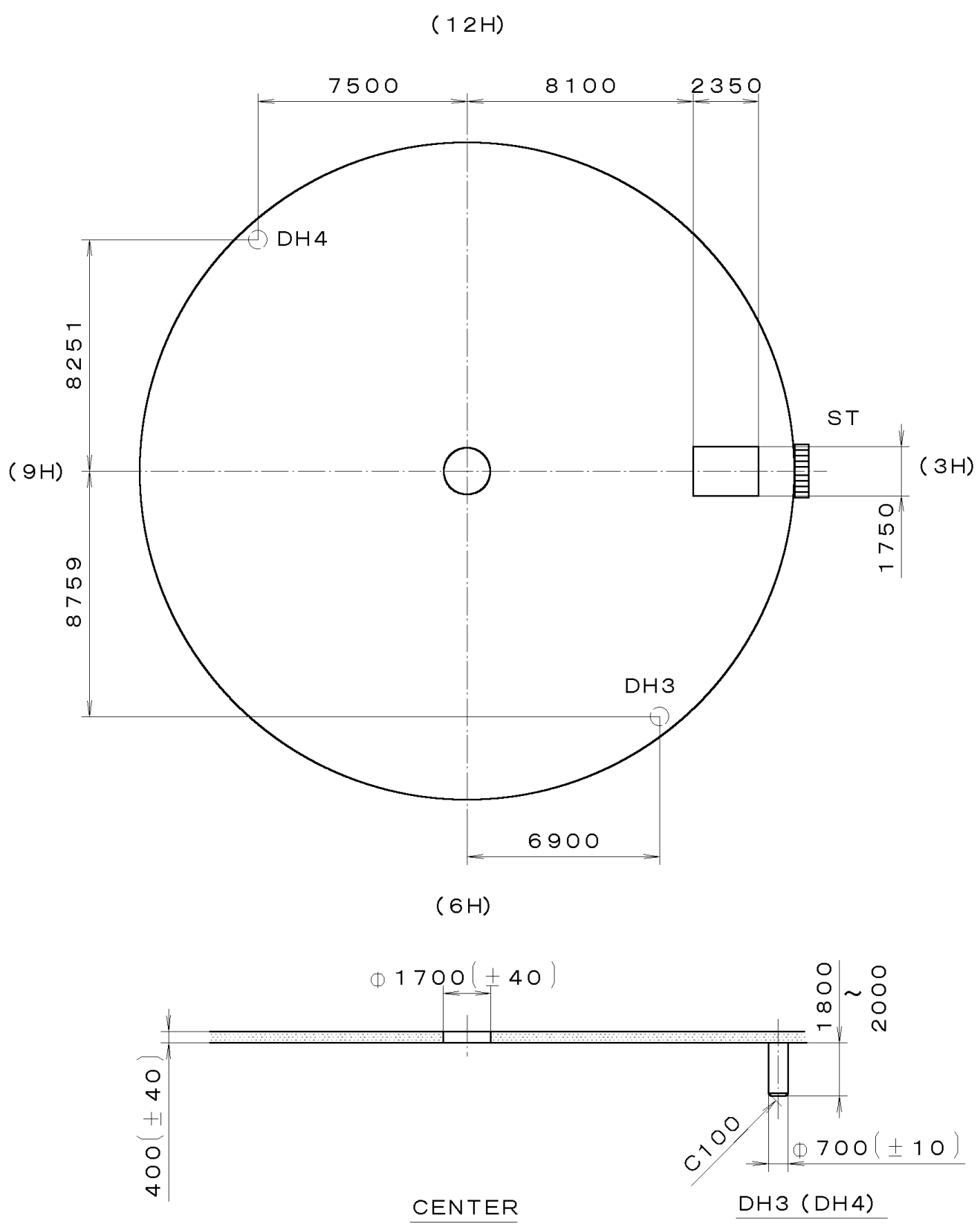

7			Quantity		Cal. No. :	1M12-10A
6			Unit	1/1000 mm	Parts:	
5			Scale	5:1	Name:	Indications for Dial
4			Date		Drawing No. : 1M12D000	
3			Drawn			
2			Checked	T. Hiruta		
1			Approved			
Material						
Heat Treatment			General Tolerances			
Hardness			Dimensions			
Plating			Angles			

This drawing is provisional and subject to our reconfirmation and/or revision without notice.

(01) *** (2100 1121) 00-06-29
 1M12-10Z
 *** TIPW

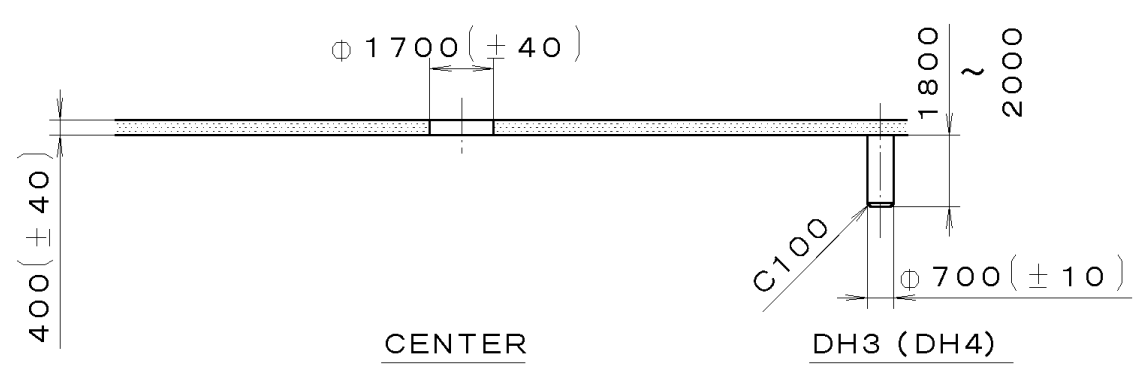
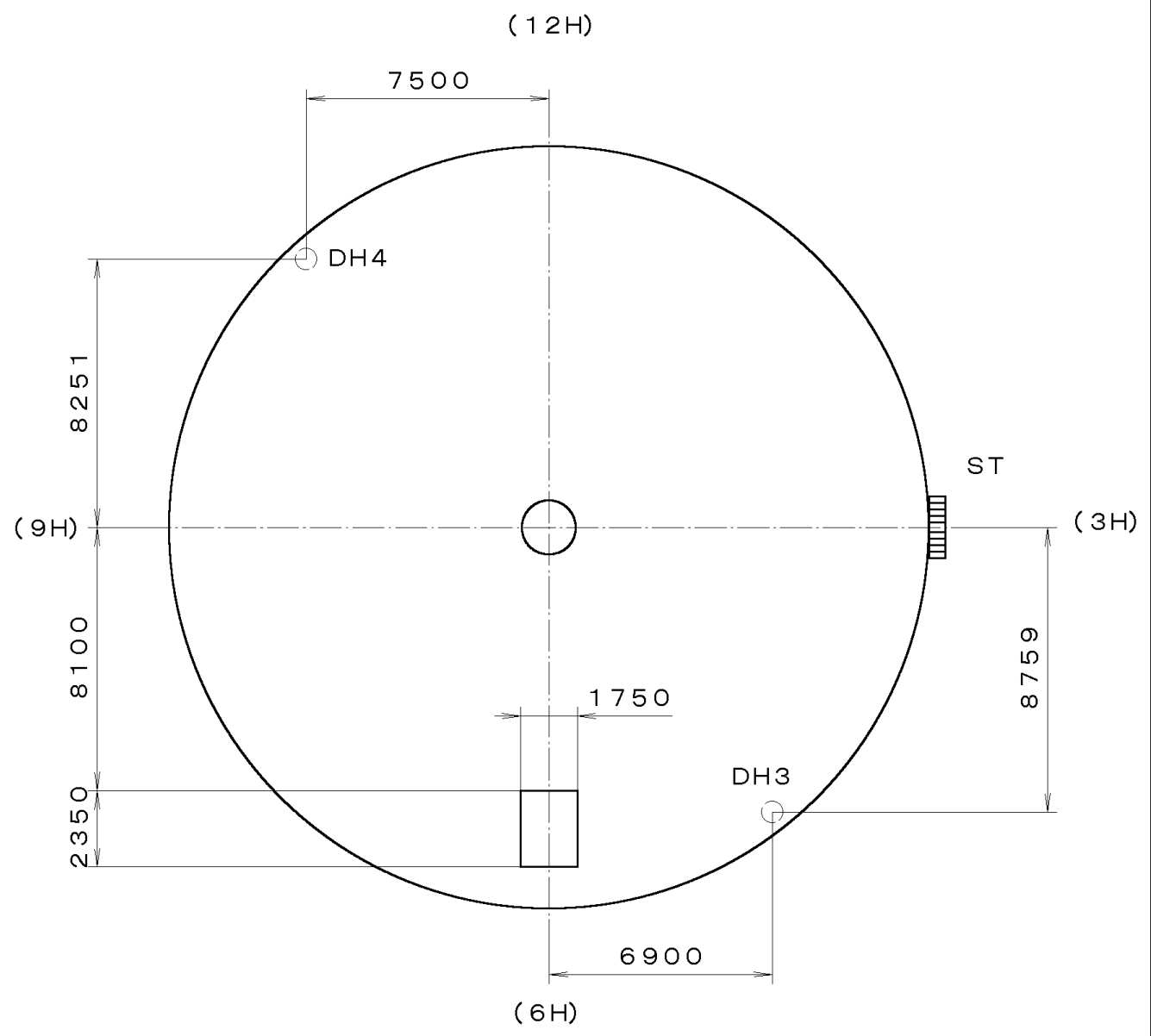

7			Quantity		Ca l. No. :	1M12-10Z
6			Unit	1/1000 mm		
5			Scale	5:1	Parts:	
4			Date			
3			Drawn			
2			Checked	T. Hiruta	Name:	
1			Approved		Indications for Dial	
Material			Drawing No. : 1M12D020			
Heat Treatment			General Tolerances			
Hardness			Dimensions			
Plating			Angles			

This drawing is provisional and subject to our reconfirmation and/or revision without notice.

*** T I P W (01) *** (2100 1121 A-01 A-01) 00-06-22

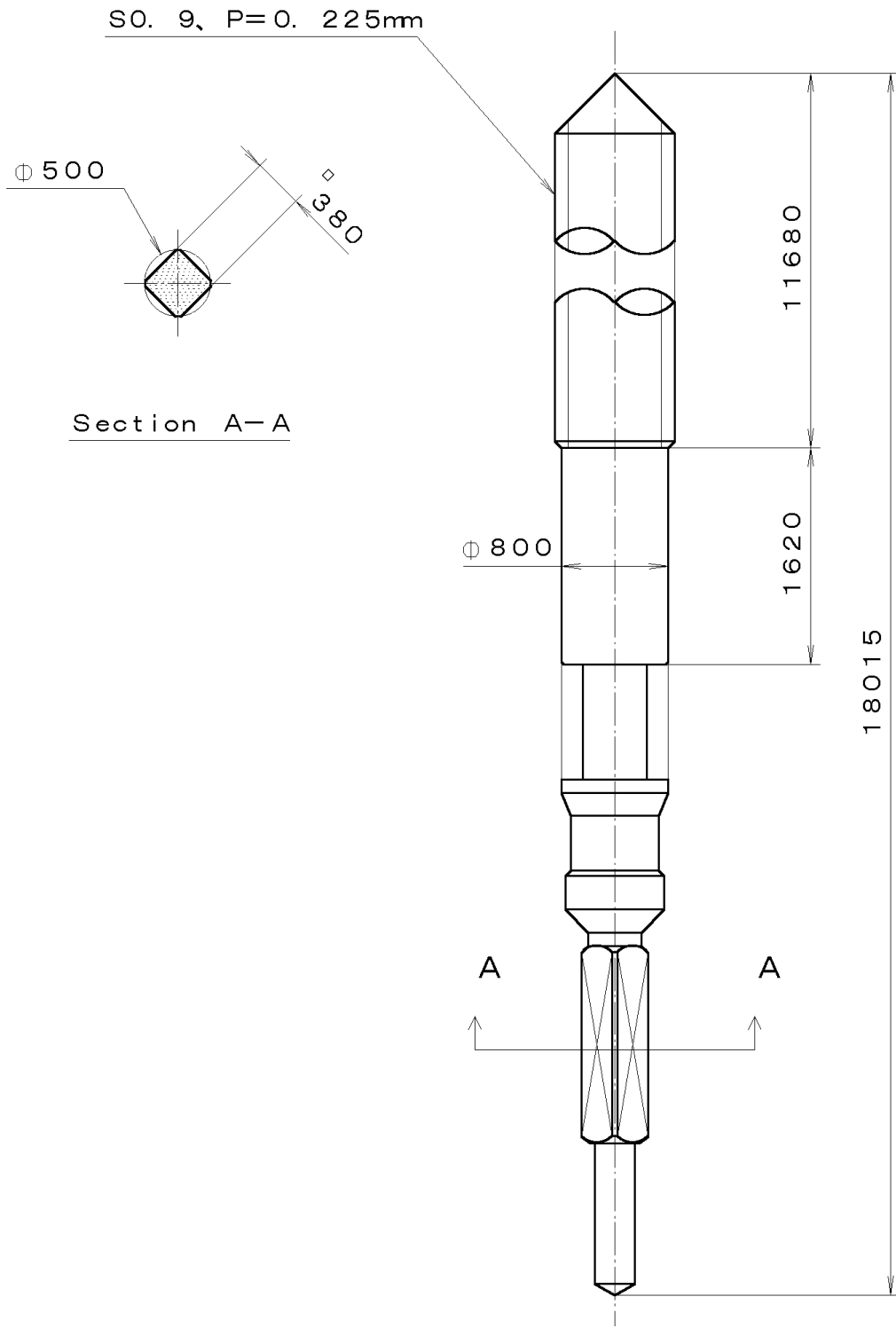

7			Quantity		Ca l. No. :
6			Unit	1/1000 mm	
5			Scale	20:1	Parts:
4			Date		065-505
3			Drawn		
2			Checked	T. Hiruta	Name:
1			Approved		SETTING STEM
Material					Drawing No. : 5050S000
Heat Treatment			General Tolerances		
Hardness			Dimensions		
Plating			Angles		